

# HAMMOND MANUFACTURING™

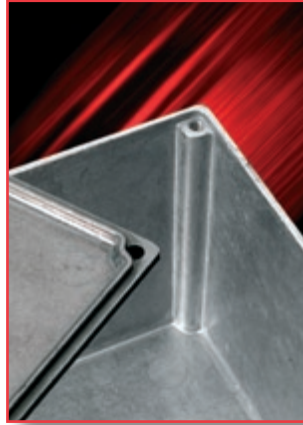

**Die-cast and GRP  
enclosures**

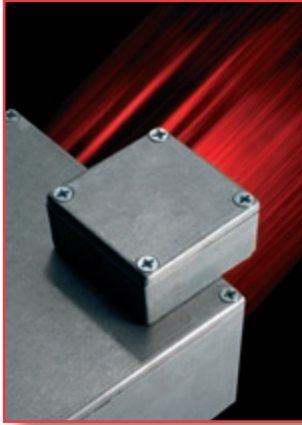

## Features

- Die-cast aluminium alloy
- Robust
- Lightweight
- Excellent EMC performance
- Easily machined
- Sealed to IP54
- Shallow lids
- Supplied in natural finish

## Technical details

- Aluminium alloy to BS1490, LM2M
- Lids secured using 4 off M3.5 x 12 Pozidriv # 2 Taptite screws
- Countersunk lid holes
- Two-piece "lap joint" construction

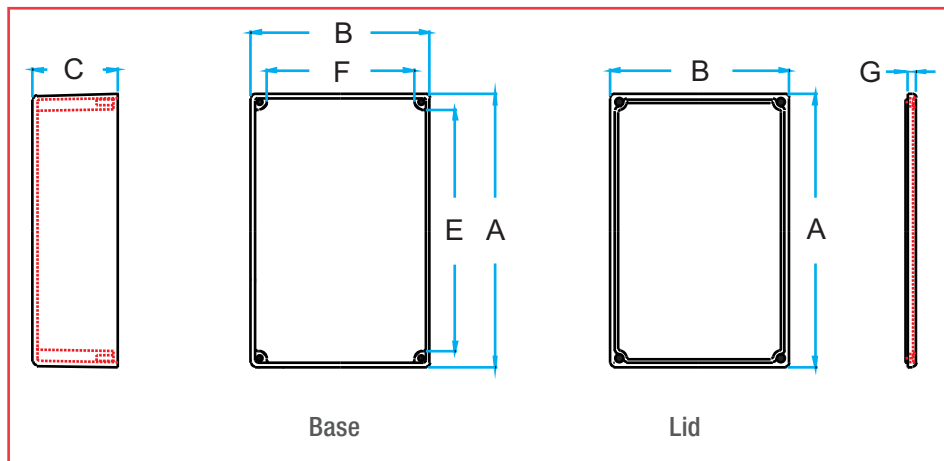

Part Number	Dimensions					Lid Height	
	A	B	C	E	F	G	
			No lid				
70007	50	50	21	30	30	4	
11451PSLA	53	38	27	36	22	4	
27969PSLA	92	38	27	76	22	4	
70009	92	92	38	67	67	4	
27134PSLA	111	60	27	94	44	4	
29830PSLA	120	95	30	104	79	4	
26908PSLA	120	95	53	104	79	4	
70011	125	125	53	105	105	4	
11130PSLA	125	125	75	109	109	4	
10758PSLA	145	95	45	129	79	4	
26827PSLA	188	120	53	170	103	4	
26357PSLA	188	120	78	170	103	4	

Typical wall thickness 2mm  
All dimensions in mm

*Thin wall*

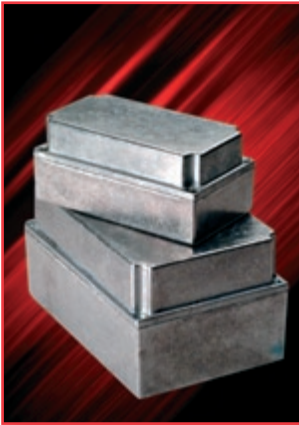

## Features

- Die-cast aluminium alloy
- Robust
- Lightweight
- Excellent EMC performance
- Easily machined
- Sealed to IP54
- Deep lids
- Supplied in natural finish

## Technical details

- Aluminium alloy to BS1490, LM2M
- Lids secured using 4 off M3.5 x 12 Pozidriv # 2 Taptite screws
- Countersunk lid holes
- Two-piece "lap joint" construction

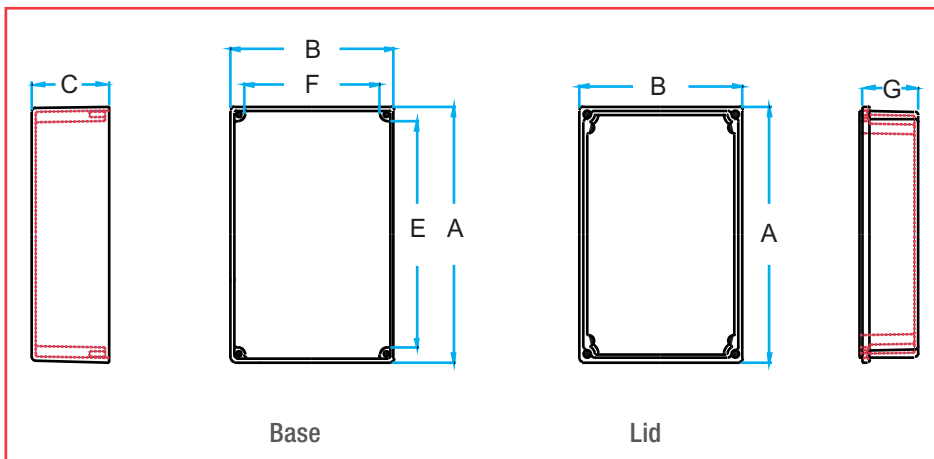

Part Number	Dimensions					Lid Height	
	A	B	C	E	F	G	
			No lid				
27134PDLA	111	60	27	94	44	23	
29830PDLA	120	95	30	104	79	40	
26908PDLA	120	95	53	104	79	40	
11130PDLA	125	125	75	109	109	32	
10758PDLA	145	95	45	129	79	32	

Typical wall thickness 2mm  
All dimensions in mm

*Thin wall deep lid*



## Features

- Die-cast aluminium alloy
- Robust
- Typical wall thickness 4mm
- Lightweight
- Excellent EMC performance
- Easily machined
- Tongue and groove construction
- Integral extruded silicon rubber gasket
- Lids secured outside sealed area
- Sealed to IP65
- Through box, blind hole wall mounting outside sealed area
- Internal grounding screws fitted (some models)
- Lid grounding screws (some models)
- Supplied in natural smooth brushed finish
- Supplied in back or grey RAL 7001 powder coat

## Technical details

- Aluminium alloy to BS1490, LM6
- Lids secured using 4 off recessed self-captivated stainless steel screws, M4 or M6 depending on box size
- 2 drilled and tapped M4 holes for mounting or grounding in the 1590Z110, 130 and 135 sizes
- 1 drilled and tapped M4 grounding hole in the lid of the 1590Z135 and 160 sizes
- M4 x 6 copper grounding screws supplied where required

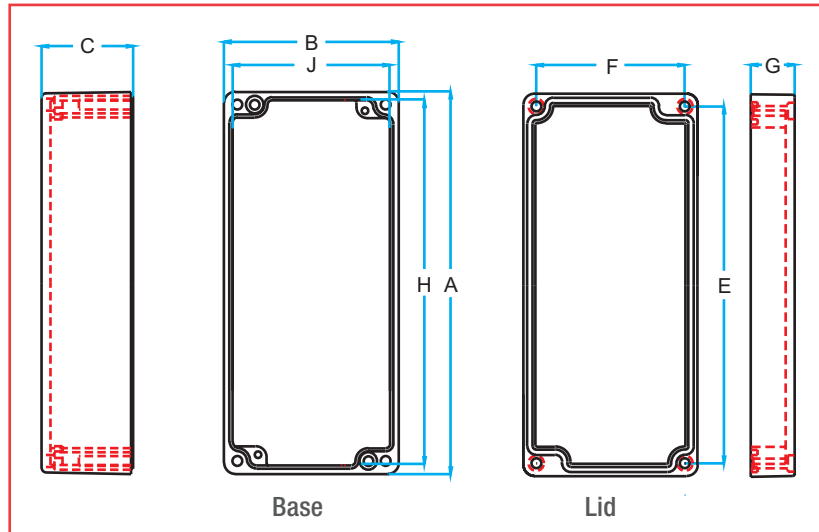

Watertight 1590Z

Part Number	Dimensions									Lid Ground Screw	
	A	B	C	E	F	G	H	J			
			No lid								
	Natural	Black	Grey								
1590Z060	1590Z060BK	1590Z060GY	50	45	24	40	36	6	45	40	✓
1590Z061	1590Z061BK	1590Z061GY	64	58	26	52	46	10	56	50	✗
1590Z110	1590Z110BK	1590Z110GY	75	80	40	63	68	12	67	72	✗
1590Z062	1590Z062BK	1590Z062GY	98	64	26	86	52	10	90	56	✗
1590Z063	1590Z063BK	1590Z063GY	150	64	26	137	51	10	141	56	✗
1590Z130	1590Z130BK	1590Z130GY	175	80	40	163	68	12	167	72	✗
1590Z135	1590Z135BK	1590Z135GY	175	80	40	163	68	20	167	72	✓

Typical wall thickness 4mm  
All dimensions in mm



## Features

- Die-cast aluminium alloy
- Robust
- Typical wall thickness 4mm
- Lightweight
- Excellent EMC performance
- Easily machined
- Tongue and groove construction
- Integral extruded silicon rubber gasket
- Lids secured outside sealed area
- Sealed to IP65
- Through box, blind hole wall mounting outside sealed area
- Integral mounting shelf in base
- Internal grounding screws fitted (some models)
- Lid grounding screws (some models)
- Supplied in natural smooth brushed finish
- Supplied in black or grey RAL 7001 powder coat

## Technical details

- Aluminium alloy to BS1490, LM6
- Lids secured using 4 off recessed self-captivated stainless steel screws, M4 or M6 depending on box size
- 6 drilled and tapped M4 mounting or grounding holes, three in each base area
- 1 drilled and tapped M4 grounding hole in the lid of the 1590Z119, 160, 231 and 162 sizes
- M4 x 6 copper grounding screws supplied where required

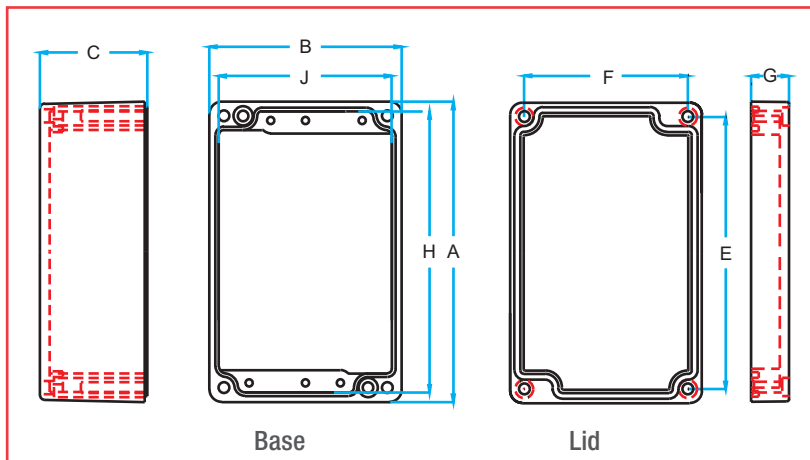

Part Number			Dimensions								Lid Ground Screw
Natural	Black	Grey	A	B	C No lid	E	F	G	H	J	
1590Z100	1590Z100BK	1590Z100GY	75	80	40	63	68	12	67	72	X
1590Z119	1590Z119BK	1590Z119GY	122	120	60	106	104	20	112	111	✓
1590Z120*	1590Z120BK*	1590Z120GY*	125	80	43	113	68	15	117	72	X
1590Z160	1590Z160BK	1590Z160GY	160	160	70	141	141	20	152	152	✓
1590Z231	1590Z231BK	1590Z231GY	200	230	92	180	210	20	191	215	✓
1590Z150*	1590Z150BK*	1590Z150GY*	220	120	60	205	104	20	211	111	X
1590Z162	1590Z162BK	1590Z162GY	260	159	70	240	140	20	251	151	✓

Typical wall thickness 4mm  
All dimensions in mm

\* The 1590Z120 functionally replaces the previously available 9732PSLA  
\* The 1590Z150 functionally replaces the previously available 9920PSLA

*Watertight 1590Z with shelf*

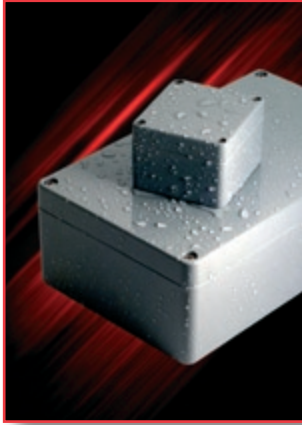

## Features

- Moulded from glass reinforced polyester
- Robust
- Typical wall thickness 5mm
- Lightweight
- Excellent chemical resistance
- Easily machined
- Tongue and groove construction
- Integral neoprene rubber gasket
- Lids secured outside sealed area
- Sealed to IP65
- Through box, blind hole wall mounting outside sealed area
- Integral mounting shelf in base
- Internal moulded-in mounting nuts in base
- Supplied in natural finish

## Technical details

- Moulded from glass reinforced polyester
- Lids secured using 4 off recessed self-captivated stainless steel screws, M4 or M6 depending on box size
- 6 M4 mounting nuts moulded into the base

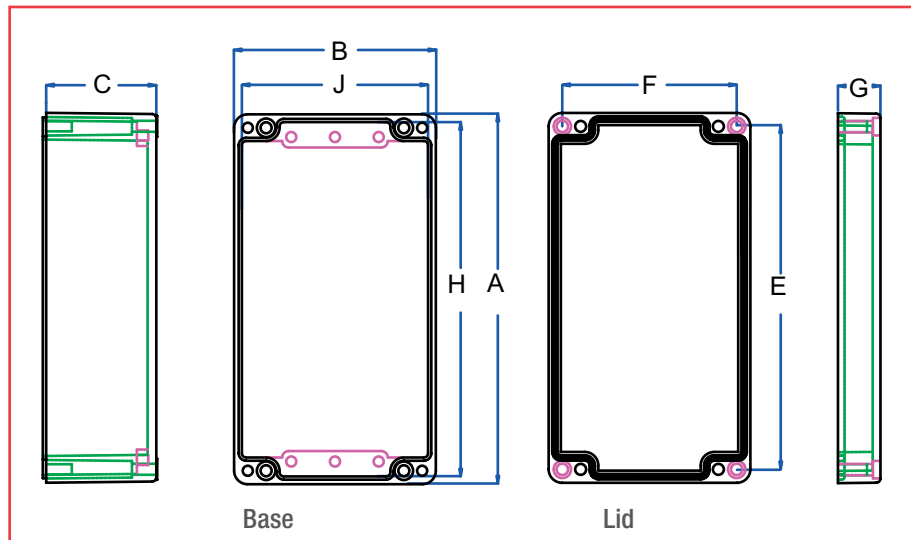

Part Number	Dimensions							
	A	B	C	E	F	G	H	J
No lid								
Grey								
1590ZGRP081	80	75	40	66	61	15	70	65
1590ZGRP082	110	75	40	94	60	15	99	64
1590ZGRP121	120	122	65	106	104	25	111	110
1590ZGRP083	160	75	40	134	62	15	151	65
1590ZGRP161	161	160	70	139	140	21	147	146
1590ZGRP123	220	120	65	205	104	25	210	109
1590ZGRP162	260	160	70	240	140	21	247	147

Typical wall thickness 5mm  
All dimensions typical  
All dimensions in mm

Watertight 1590ZGRP



## Features

- Factory modified to your specification
- Fast prototype turnaround time
- Economical for pre-production, start-up and production quantities
- Machining
- Silk screening
- Hot stamping
- Special colours
- Custom materials
- Custom kitting and packaging

## Technical details

- Easy quotation request and order procedure
- Download the full size drawings from our web site [www.hammondsales.com](http://www.hammondsales.com)
- Download the AutoCAD files from our web site [www.hammondsales.com](http://www.hammondsales.com)
- Mark up the drawings or amend the AutoCAD files
- email your files to the address on the rear cover
- Receive your quotation
- Place your order



**Machining**

**Silk screening**

**Hot stamping**

**Special colours**

**Custom materials**

*Customised products*